

**How to Cite:**

Tung, P. H., & Ly, L. T. K. (2021). Influence of personality traits on people's satisfaction with public service in Hanoi city, Vietnam. *Linguistics and Culture Review*, 5(S4), 2341-2364. <https://doi.org/10.21744/lingcure.v5nS4.1968>

# **Influence of Personality Traits on People's Satisfaction with Public Service in Hanoi city, Vietnam**

**Phuong Huu Tung**

Faculty of Human Resource Management, Ha Noi University of Home Affairs, Vietnam

**Le Thi Khanh Ly**

University of Economics and Business, Vietnam National University, Hanoi, Vietnam

**Abstract**---The quality of public services is concerned and improved to meet the satisfaction of the people, which has made governments more aware of the need to provide public services according to the needs and preferences of the public. Most of the previous studies used qualitative methods to assess people's satisfaction with public services. The authors use a quantitative research method to explore the quality of public services in Vietnam using the Servqual model and explore the relationship between personality traits and satisfaction with public services. The study was conducted in OSS rooms in Hanoi city, Vietnam in June 2021, using the intentional sampling method. Collect data through survey of 500 votes, of which 350 valid votes of citizens. The results of analysis by SEM model show that all 5 elements of personality traits: Openness, Dedication, Neuroticism; psychic; Greableness has a positive and significant influence on the remaining 5 factors through 2 coefficients, Regression Weights and P-value, both have reliable values. The conclusion of this study provides valuable data for Government policymakers.

**Keywords**---citizen satisfaction, Hanoi city, personality traits, public service, Vietnam.

**Introduction**

To measure the quality of public services, researchers have advocated using the Servqual Model (Wisniewski, 1996; Rowley, 1998; Wisniewski, 1996; Brysland & Curry, 2001). Brysland & Curry (2001), states that the literature supports using the Servqual Model in the public sector. In addition, Caron & Giauque (2006)

Linguistics and Culture Review © 2021.

**Corresponding author:** Ly, L. T. K.; Email: [khanhlyt@ynu.edu.vn](mailto:khanhlyt@ynu.edu.vn)

Manuscript submitted: 18 August 2021, Manuscript revised: 09 Oct 2021, Accepted for publication: 27 Nov 2021

point out that public sector employees face new professional challenges arising from introducing new principles and tools inspired by the transition of new public management. Studies on the relationship between personality characteristics and people's satisfaction with public services have also recently appeared (Kim et al., 2016; Castillo, 2017; Ciunova-Shuleska & Palamidovska-Sterjadovska, 2019).

In Vietnam, public services include three types: public services in non-business, public services in the field of public utilities and public services in state administration, also known as public administrative services (Tan & Waheed, 2014). Public services, including activities that provide essential social welfare for people such as education, culture, science, health care, sports, insurance, social security. The current trend in the world is that the State only performs public services that society cannot or does not want to do, transferring part of this type of public service to the private sector and the public social organization (Arshad & Ameen, 2010; Bhattacharya et al., 2016).

In Vietnam so far, there have been quite a few studies on the theory and practical application of public service evaluation from large to small scale. On a national scale, there are provincial competitiveness indexes (PCI), administrative reform index (PAR), provincial public administration and governance performance index (PAPI), satisfaction index on administrative services (SIPAS). These indicators are calculated annually and organized on a large scale, which is meaningful and plays an essential role in the general assessment of public administrative services, but only used to determine at the provincial level or higher (Cronin Jr & Taylor, 1994; Gowan et al., 2001). With rather cumbersome questionnaires, most of the methods of calculation and analysis are complicated and expensive and cannot be widely applied for the provinces to calculate and evaluate themselves on a small scale. The narrow range includes departmental, sectoral and local competitiveness index (DDCI). It is an index developed from the PCI Provincial Competitiveness Index; the object of the study is businesses, intending to evaluate the operation of local governments and departments during the year. Several foreign organizations such as Oxfam have also funded and piloted several grassroots public service quality assessment projects in Vietnam. However, these pilot projects have not been widely deployed, are unstable, and have some limitations in the implementation process and the calculation and analysis of the results (Zenker & Rütter, 2014; Nigro & Cisaro, 2016).

At present, there are few quantitative studies on people's satisfaction with public services. In the past ten years, such as Khanh (2011), public studies measure satisfaction with public administrative services at the People's Committee of District 1, HCMC. Ho Chi Minh City shows people's satisfaction with public administrative services at the People's Committee of District 1, Ho Chi Minh City. Ho Chi Minh City is influenced by four critical factors: procedures, serviceability, reliability, facilities. Meanwhile, conducted a study on people's satisfaction with public administrative services at the People's Committee of Dak Ha District, Kon Tum province. Research shows six factors affecting people's satisfaction with public administrative services: Reliability, process, procedures, staff, cost and time, facilities, care and support for people. Nguyen & Quang, explores three factors affecting people's satisfaction with the OSS mechanism: (1) Reflection and

tangible means; (2) Quality of human resources; (3) Process of handling the application. In particular, the quality of human resources is the factor that has the most substantial impact on people's satisfaction. [Ngo & Nguyen \(2016\)](#), explores six factors affecting people's satisfaction with the quality of public administrative services: Facilities, reliability, staff capacity, service attitude, empathy, Procedures. [Khanh \(2011\)](#), when assessing people's satisfaction with tax administrative procedures. The author has discovered seven factors that positively affect people's satisfaction: facilities, transparency, service capacity, responsiveness, reliability, democratic fairness, and openness. Empathy affects the satisfaction of taxpayers, in which reliability has the highest impact on the satisfaction of taxpayers ([Mukhtar et al., 2013](#); [Khan et al., 2020](#)). Thus, quantitative studies exploring the quality of public services in Vietnam using the Servqual Model and exploring the relationship between personality traits and satisfaction with public services are lacking. This study aims to complement the quantitative research on this issue and present the implications of the findings for the government ([Phap et al., 2020](#); [Uy & Nakagoshi, 2008](#)).

## Literature reviews

### Service quality

Service quality measures the extent to which the service provided matches the customer's expectations. Providing quality service means meeting customer expectations consistently ([Lewis & Booms, 1983](#)). Wisniewski defines service quality as the difference between the customer's expectations and the perceived service ([Winiewski, 1996](#)). Service quality is the extent to which a service meets customer expectations ([Lewis & Mitchell, 1990](#); [Dotchin & Oakland, 1994](#); [Asubonteng et al., 1996](#); [Wisniewski, 1996](#)). It can be concluded that service quality is the difference between service expectations and perceived service. If expectations are more remarkable than performance, perceived quality will be less satisfactory, and customer dissatisfaction occurs ([Parasuraman et al., 1985](#); [Lewis & Mitchell, 1990](#)). [Parasuraman et al. \(1985\)](#), determined that service quality is the difference between expectations and perceptions. Therefore, it is easily measured by averaging the scores obtained from five quality factors ([Brown et al., 1992](#)).

The most accepted model for measuring service quality is the Servqual Model ([Parasuraman et al., 1985](#); [Parasuraman et al., 1991](#); [Parasuraman et al., 1994](#)). The Servqual Model is a multidimensional model used to measure the quality of any service provider organization. It was developed by ([Parasuraman et al., 1985](#)). This model was initially developed for the marketing sector, and it later proved to be adequate to determine the quality of other institutions such as hospitals, telecommunications, libraries, schools, colleges and many other media centers ([Kettinger & Lee, 1994](#); [Nitecki, 1996](#)). The Servqual Model includes factors (tangibles, reliability, responsiveness, empathy and assurance) ([Ahmed & Samreen, 2011](#)). Consumers judge service quality by the gaps between their expectations from service providers and their experience ([Brose et al., 2005](#); [Ashton et al., 2014](#)).

Table 1  
 Overview of items in the SERVQUAL model (Parasuraman et al., 1988)

Rate	Number of items in the Questionnaire	Definition
Reliability	5	Ability to perform promised services reliably and accurately
Assurance	4	Knowledge, courtesy of employees and their ability to convey trust and confidence
Tangibles	4	Appearance of facilities, equipment, personnel and communication materials
Empathy	5	Ability to provide personal attention and care to customers
Responsiveness	4	Willingness to help customers and provide service quickly

Critics of the Servqual model argue that the model is not universal (Vandamme & Leunis, 1993). They also say that the model cannot explain statistical, economic and psychological aspects (Francis, 1994). They say there is no evidence that customers claim service quality is the gap between their expectations and the perception of what they are getting from that particular organization. In addition, the entire model focuses on service delivery and not service outcomes (Francis, 1994).

### Public service and public service quality

Public services are entirely dependent on state finances and non-profit nature (Shaw, 2004). Improving the quality of public services stems from citizen participation in the public sector, stimulating greater transparency and allowing local people to assess the quality, adequacy and effectiveness of public services to express their needs and preferences. In addition, it helps them engage in innovative proposals to enable better use of public funds and improve service delivery (Ringold et al., 2011).

Public service quality is an elusive, ambiguous construct (Parasuraman et al., 1985; Gronroos, 1988; Gronroos, 1957). This challenge comes with a greater need to assess the quality of services in the public sector, especially given the implicit obligation of the public sector to ensure that services are delivered efficiently. The importance of public services should also be highlighted in the current study. Evaluating the quality of public services has an essential role in shaping the formulation and practice of policies and programs for the common good of citizens (Kumasey, 2014). In public sector organizations, providing customer service is one of the crucial factors contributing significantly to building a good reputation and reputation in the community (Nadiha et al., 2010).

As well as measuring service quality in general, the Servqual Model is also used to measure public service quality around the world. In Scotland, for example, [Wisniewski \(1996\)](#), discussed the key issues that public sector organizations need to address in their search for an adequate measure of service quality, assessing potential functionality of the Servqual tool for the public sector and reports on its adoption for the public library service. In 2001, Maryland and Curry explained the new context in which public services are provided, emphasizing improving service quality. The Servqual tool was used in this study to improve both process management and strategic planning in the Northern Lanark Shire Council ([Bryslund & Curry, 2001](#)). In Malaysia, Sharifuddin, used the Servqual tool to measure service quality at ten public transport departments. [Ramseook-Munhurrin et al. \(2010\)](#), applied the Servqual tool to understand the level of service quality provided in Mauritian public services by investigating the match between customer expectations and employees' perceptions of customer expectations row ([Epple & Romano, 1996](#); [Francois, 2000](#)).

### **Big five personality traits**

Personality is an individual psychological attitude that determines how individual acts and reacts to his environment. Personality is expressed in the individual's attitude system and in the will qualities of man. In other words, an individual's personality is a combination of psychological characteristics by which we can distinguish this individual from others. Several factors affect the formation of an individual's personality: congenital, genetic, nurturing, learning, socio-cultural environment, circumstances, and situations. There are many models of personality research. The Big Five is an essential tool for assessing different aspects of a person's personality ([Gerber et al., 2010](#)). Psychologists suggest that personality can be summarized by five characteristics ([John et al., 2008](#); [McCrae & Costa 2008](#)). Multiple methodological analyses have concluded that the five characteristics capture vital dimensions of individual variation ([John et al., 2008](#); [McCrae & Costa 2008](#)).

The five core traits are extroversion, agreeableness, openness, conscientiousness, and sensitivity ([Gerber et al., 2010](#)). The Big Five model has been applied to many different research fields, such as predicting general prejudice [Ekehammar & Akrami \(2003\)](#); [Sibley & Duckitt \(2008\)](#), racism [Jackson & Poulsen \(2005\)](#); [Silvestri & Richardson \(2001\)](#), attitudes toward immigrants [Akrami et al. \(2011\)](#), political ideology [Carney et al. \(2008\)](#); [Jost et al. \(2008\)](#); [Jost \(2006\)](#), politics ([Hibbing et al., 2011](#); [Gerber et al., 2011](#); [Mattila et al., 2011](#); [Mondak & Halperin, 2008](#); [Mondak, 2010](#); [Mondak & Halperin, 2008](#)).

The five personality traits of individuals manifest in different cultures. Therefore, individuals must be placed in specific situations to understand their personality ([Allik & McCrae, 2004](#); [Heine & Buchtel, 2009](#); [Schmitt et al., 2007](#); [Denissen & Penke, 2008](#); [Mischel & Shoda, 1995](#); [Canli, 2008](#)). The five personality traits provide a compelling explanation of social attitudes and behaviour because they are internal to the individual, preceded by adult social experiences: it has a significant heritability ([Medland & Hatemi, 2009](#); [Yamagata et al., 2006](#)). Personality stabilizes in adulthood ([Caspi et al., 2005](#); [Hampson & Goldberg,](#)

2006; Terracciano et al., 2010). Personality traits are related to economic, social, and political attitudes and behaviours (Gerber et al., 2010, 2011; Mondak, 2010; Mondak & Halperin, 2008; Mondak et al., 2010).

In addition, five major personality factors have been studied to compare the suitability and decision of an individual's career choice (Barrick & Mount, 1991; Barrick et al., 2001). In the civil field, individuals with a high self-control index often adhere to the principles and standards of the organization, work hard and persevere in work plans. On the other hand, individuals with low self-esteem often show disorganized, quit, irresponsible, careless, negligent and impulsive behaviour at work (Jin et al., 2009).

Table 2  
The big five personality dimensions

Trait	Characteristics associated with the trait
Extroversion - Intraversion	Sociable, gregarious (vs. Reserved), assertive, talkative, active
Neuroticism - Emotional Stability	Anxious/nervous (vs. Relaxed), depressed, angry, embarrassed, emotional, worried, insecure
Agreeableness - Antagonism	Courteous/considerate/kind (vs. Rude), flexible, trusting, good-natured, cooperative, forgiving, soft-hearted, tolerant
Conscientiousness - Lack of Direction	Dependability: careful, thorough, responsible, organized, planful - volitional aspects: hardworking (vs. Lazy), achievement-oriented/effective, persevering
Open to Experience - Closed to Experience	Imaginative, cultured, curious/eager for knowledge, original, broad-minded, intelligent, artistically sensitive

Source: Barrick & Mount, 1991

### Relationship between big five and service satisfaction

Studies on the relationship between personality traits and customer satisfaction are mainly in the private sector. Ciunova-Shuleska & Palamidovska-Sterjadovska (2019), link personality traits, influence, and customer satisfaction in a model that provides evidence-based insights into structural relationships between personality traits, influence and customer satisfaction. Furthermore, this is the first study to explore the relationship between personality traits, influence and customer satisfaction on retail banking customers in a developing country in the Balkans. Research in the retail sector in Beijing, China, found a link between the role of personality traits on the relationship between customer satisfaction and loyalty in North China. Kinsh, China. Specifically, consumer superiority is positively associated with cumulative loyalty, while Neuroticism consumer characteristics reduce the association between customer satisfaction and loyalty (Mondak et al., 2010; Marušić et al., 2011; Zakaria et al., 2010).

Siddiqui (2012), examined the relationship between personality factors and customer satisfaction with services. The author argues that most previous studies have been directed towards establishing a relationship between individual

personality traits and purchasing behavior or predicting sales of expensive items such as automobiles, which calculates Way is not the only influencing factor. Almost all previous research on personality traits and consumer decision-making has studied products, not services. The personality aspects agreeableness (humility, altruism) and trust were consistent in providing the utmost predictive power predicting customer satisfaction for the two services (Siddiqui, 2012). In contrast, current research is aimed at customer satisfaction rather than purchasing behavior; and constructs a conceptual framework for services rather than products. If they have high scores on most personality traits, service quality plays a lesser role in activating customer loyalty (Musatova et al., 2009). Empirical research has proven the hypothesis. That customer perceived satisfaction is related to personal characteristics. Exploring the interplay of personality traits, suitability, and satisfaction is essential for influencing customers' coffee. Kim et al. (2016) discovered that personality traits directly influence customer suitability and satisfaction, two factors that determine brand loyalty (Johansson et al., 1996; Lin et al., 2013).

Castillo (2017) investigated how consumer personalities tend to prioritize different aspects of the retail business environment. Most recently, studying current banking service users in Macedonia, Ciunova (2019) modelled personality traits, influence and satisfaction in banking services. The author discovered that people with neuroticism personalities positively influence, and extraversion personalities positively affect customer satisfaction. Castillo (2017), suggests that consumers associated with personality traits such as Openness, Conscientiousness and Agreeableness are the ones who will tend to feel more satisfied with the service. The personality traits conscientiousness and agreeableness demonstrate a strong relationship with customer satisfaction. Considering consumer satisfaction should consider focusing more on consumer personality traits (Anitsal & Anitsal, 2009; Mulyanegara et al., 2009; Rammstedt & John, 2007; Žabkar & Kolar, 2010).

### **Research hypothesis**

Based on the analysis of the studies in the above sections, we propose the following research hypotheses:

- H1. Openness has a positive and significant impact on five factors (reliability, assurance, intangibles, empathy, and responsiveness).
- H2. Conscientiousness has a positive and significant impact on five factors (reliability, assurance, intangibles, empathy, and responsiveness)
- H3. Extraversion has a positive and significant impact on five factors (reliability, assurance, intangibles, empathy, and responsiveness).
- H4. Agreeableness has a positive and significant impact on five factors (reliability, assurance, intangibles, empathy, and responsiveness).
- H5. Personality neuroticism has a positive and significant impact on five factors (reliability, assurance, intangibles, empathy, and responsiveness).

## Materials and Methods

### Variables and measures

A self-assessment questionnaire was built by translating the Servqual questionnaire and Big Five questionnaire from English to Vietnamese based on reference to experts in languages, economics and psychology. After completing the questionnaire, we conducted a survey and analyzed the trial with adjustment. The questionnaire was completed after four times of grammar corrections to suit Vietnamese people. The questionnaire consists of three parts: a survey of information on the population including gender, work area; the part of Servqual independent variables includes five factors including (tangibles, reliability, responsiveness, assurance and empathy) with 22 items (Parasuraman et al., 1985). Each item is measured on a 7-point Likert scale (Disagree strongly =1; Disagree a little = 2; Disagree somewhat =3; Neither agree nor disagree =4 ; Agree somewhat = 5; Agree a little = 6; Agree Strongly =7). The dependent variables part includes five factors in the Big Five model (John & Srivastava, 1999): extraversion, agreeableness, conscientiousness, neuroticism and openness). Each item is measured on a 5-point Likert scale (Disagree strongly =1; Disagree a little = 2; neither agree nor disagree =3; Agree a little = 4; Agree Strongly =5). Items with the symbol "R" are swapped in reverse (Linde, 2021; Ramos et al., 2021).

### Data collection

The design used for the study is a cross-sectional survey design that aims to measure the relationship between individual personality factors (Big Five) and SERVQUAL factors. The study was conducted in one-stop rooms in Hanoi city in June 2021. Intentional sampling method. Collect data through a survey of 500 votes (n=350) for customers. Respondents mark items into the appropriate choices with a pencil. Collected data were analyzed using SPSS 2.0 and SPSS AMOS 2.0 software. Demographic information, including gender and previous living abroad status, is described in Table 3.

Table 3  
Frequency analysis

Factors	Gender				Total	Percentage	
	Male (n)	%	Female (n)	%			
Education	High school or less	271	54.2	98	19.6	369	73.8
	Bachelor or technical degree	47	9.4	49	9.8	96	19.2
	Honours or higher	16	3.2	19	3.8	35	7
Sector	Public sector	64	12.8	58	11.6	122	24.4
	Private Sector	270	54	108	21.6	378	75.6

## Results

### Reliability analyses

Table 4 shows that the Cronbach's Alpha coefficient of all items is more significant than 0.8, which is enough to analyze the following steps (Hair et al., 2010). Good Composite Reliability for a defined construct with five to eight items to meet the minimum threshold of 0.80 (Raykov 1997; Brunner & Süß 2005). Table 4 shows the items with aggregate confidence greater than 0.8. Thus, the items in the article are satisfactory to perform the analysis of the next steps. The threshold for accepting variance extracted (Average Variance Extracted) of items greater than 0.50 is satisfactory (Hair et al., 2010; Cortina, 1993). Table 4 shows that items including (openness, conscientiousness, agreeableness and extraversion) with the extracted variance of approximately 0.5 are still acceptable because if Average Variance Extracted < 0.5, but composite reliability is higher than 0.6, the convergent validity of the construct is still adequate (Fornell & Larcker, 1981). The remaining items with extracted variance > 0.5 satisfy the requirements for the analysis of the next steps (John & Srivastava, 1999; Joseph Jr, 2014).

Table 4  
Reliability analyses

Factors	Average Variance Extracted	Cronbach's alpha	Composite Reliability
Openness	0.455	0.893	0.893
Conscientiousnes	0.482	0.893	0.893
Neuroticism	0.503	0.890	0.890
Agreeablenes	0.452	0.852	0.852
Extraversion	0.442	0.826	0.826
Assurance	0.778	0.946	0.946
Reliability	0.757	0.940	0.937
Tangibles	0.752	0.924	0.924
Empathy	0.761	0.927	0.927
Responsiveness	0.765	0.929	0.929

### Factor analyses

The condition for exploratory factor analysis is to satisfy the following requirements: Factor loading > 0.5.  $0.5 \leq \text{KMO} \leq 1$ : The KMO coefficient (Kaiser-Meyer-Olkin) is an index used to consider the adequacy of factor analysis (Cerny & Kaiser 1977; Kaiser, 1974). Table 5 shows that the Bartlett test has statistical significance (Sig.=0.00), coefficient KMO=0.965. The large KMO coefficient means that factor analysis is appropriate. Bartlett's test has statistical significance (Sig. < 0.00): This is a statistical quantity used to consider the hypothesis that the variables are not correlated in the population. If this test is statistically significant (Sig. < 0.05), the observed variables are correlated in the population. Thus, the variables are valid for factor analysis (Snedecor & Cochran, 1989). Table 5 shows that the Extraction Sums of Squared Loadings of 5 factors = 62.848 % are valid

(Hair, 2014). Initial Eigenvalues of 5 factors = 1,902 (greater than 1.40) are valid (Smith & Miao, 1994).

Table 5  
KMO and Bartlett's test

KMO and Bartlett's Test			
Kaiser-Meyer-Olkin Measure of Sampling Adequacy.			.965
Bartlett's Test of Sphericity	Approx. Chi-Square		19636.104
	df		1891
	Sig.		.000

Factor loading (factor loading factor or factor weight) is the criterion to ensure the practical significance of factor analysis: Factor loading > 0.3 is considered to be the minimum level; Factor loading > 0.4 is considered important; Factor loading > 0.5 is considered to be of practical significance. Table 6 shows that the factor loading of all variables is greater than 0.5, which means that the factor analysis is valid (Hair et al., 1998). Table 5 shows that Extraction Sums of Squared Loadings = 64,286 means that the research data set has 64,286% of the variance explaining the study results. Initial Eigenvalues of 10 factors in the research model = 1,570 (>1) are valid.

Table 6  
Total variance explained

Component	Initial Eigenvalues			Extraction Sums of Squared Loadings			Rotation Sums of Squared Loadings		
	Total	% of Variance	Cumulative %	Total	% of Variance	Cumulative %	Total	% of Variance	Cumulative %
1	21.376	34.477	34.477	21.376	34.477	34.477	5.595	9.024	9.024
2	2.682	4.325	38.802	2.682	4.325	38.802	5.304	8.555	17.579
3	2.321	3.744	42.546	2.321	3.744	42.546	4.805	7.750	25.328
4	2.238	3.610	46.155	2.238	3.610	46.155	4.062	6.552	31.880
5	2.133	3.440	49.595	2.133	3.440	49.595	3.925	6.331	38.212
6	2.089	3.369	52.964	2.089	3.369	52.964	3.703	5.973	44.185
7	1.890	3.048	56.012	1.890	3.048	56.012	3.500	5.645	49.830
8	1.789	2.886	58.898	1.789	2.886	58.898	3.025	4.878	54.708
9	1.771	2.856	61.754	1.771	2.856	61.754	3.018	4.868	59.576
10	1.570	2.532	64.286	1.570	2.532	64.286	2.920	4.710	64.286

Extraction Method: Principal Component Analysis.

Table 7  
Rotated component matrix

	Rotated Component Matrix <sup>a</sup>									
	1	2	3	4	5	6	7	8	9	10
Openness1	.702									
Openness6	.668									
Openness8	.656									
Openness5	.640									
Openness9	.640									
Openness4	.635									
Openness2	.609									
Openness7	.601									
Openness10	.595									
Openness3	.581									
Conscientiousnes3		.707								
Conscientiousnes7		.666								
Conscientiousnes8		.658								
Conscientiousnes6		.655								
Conscientiousnes5		.653								
Conscientiousnes4		.651								
Conscientiousnes2		.628								
Conscientiousnes1		.620								
Conscientiousnes9		.618								
Neuroticism6			.695							
Neuroticism4			.694							
Neuroticism7			.683							
Neuroticism5			.670							
Neuroticism2			.668							
Neuroticism3			.668							
Neuroticism1			.660							
Neuroticism8			.619							
Agreeablenes1				.697						
Agreeablenes4				.687						
Agreeablenes6				.672						
Agreeablenes5				.664						
Agreeablenes3				.640						
Agreeablenes2				.620						
Agreeablenes7				.616						
Assurance4					.796					
Assurance2					.792					
Assurance5					.784					
Assurance3					.779					
Assurance1					.772					
Reliability4						.768				
Reliability2						.760				
Reliability3						.754				
Reliability5						.752				

	Rotated Component Matrix <sup>a</sup>									
	Component									
	1	2	3	4	5	6	7	8	9	10
Reliability1						.743				
Extraversion6							.671			
Extraversion2							.662			
Extraversion4							.648			
Extraversion3							.645			
Extraversion1							.639			
Extraversion5							.635			
Tangibles4								.786		
Tangibles1								.785		
Tangibles2								.775		
Tangibles3								.757		
Empathy1									.782	
Empathy4									.781	
Empathy2									.780	
Empathy3									.742	
Responsiveness3										.778
Responsiveness1										.759
Responsiveness2										.745
Responsiveness4										.740

Extraction Method: Principal Component Analysis.

Rotation Method: Varimax with Kaiser Normalization.

a. Rotation converged in 7 iterations.

### Structural equation modeling (SEM)

The SEM model is an extension of the general linear model (GLM) that allows the researcher to test a set of regression equations simultaneously. The SEM model combines all the techniques such as multivariate regression, factor analysis and correlation analysis (between elements in the network diagram) to check the complex relationship fit in the model. Unlike other statistical techniques that only allow estimation of the partial relationship of each pair of factors (elements) in the classical model (measurement model), SEM allows the simultaneous estimation of the elements in the model. The overall model estimates the causal relationship between the latent concepts (Latent Constructs) through indicators that combine both measurement and structure of the theoretical model, measure the stable relationships (recursive) and non-recursive, measuring direct and indirect effects, including measurement error and residual correlation. With the confirmatory factor analysis (CFA) technique, the SEM model allows the flexibility to find the most suitable model in the proposed models (Crowley & Fan, 1997; Kline, 2015; Nachtigall et al., 2003; Raykov & Marcoulides, 2006; Ullman, 2006; Widaman & Reise, 1997).

To evaluate the fit of the SEM model, a Chi-Square ( $\chi^2$ ) test, Root-Mean-Square Error of Approximation (RMSEA) procedure Browne & Cudeck (1993), together with a confidence interval, standardized-root-mean, is required. Square residual (SRMR), Tucker-Lewis Index (TLI) Tucker & Lewis (1973), and Comparative Fit

Index (CFI) [Bentler \(1990\)](#), were reported. It is suggested that a good fitting model should have values of CFI and TLI  $\geq .90$ , RMSEA and SRMR  $\leq .08$  ([Browne & Cudeck, 1993](#); [Byrne, 2012](#); [Hu & Bentler, 1999](#); [Kline, 2015](#)).

Table 8  
Regression weights

			Estimate	S.E.	C.R.	P	
Reliability	<---	Openness	.202	.077	2.608	.009	accept
Assurance	<---	Openness	.237	.084	2.816	.005	accept
Responsiveness	<---	Openness	.291	.084	3.479	***	accept
Empathy	<---	Openness	.300	.088	3.424	***	accept
Tangibles	<---	Openness	.190	.084	2.262	.024	accept
Reliability	<---	Conscientiousnes	.266	.073	3.632	***	accept
Assurance	<---	Conscientiousnes	.359	.081	4.460	***	accept
Responsiveness	<---	Conscientiousnes	.336	.079	4.248	***	accept
Empathy	<---	Conscientiousnes	.345	.083	4.159	***	accept
Tangibles	<---	Conscientiousnes	.278	.080	3.495	***	accept
Reliability	<---	Neuroticism	.178	.068	2.629	.009	accept
Assurance	<---	Neuroticism	.154	.073	2.095	.036	accept
Responsiveness	<---	Neuroticism	.101	.072	1.405	.160	not accept
Empathy	<---	Neuroticism	.108	.076	1.430	.153	not accept
Tangibles	<---	Neuroticism	.166	.074	2.252	.024	accept
Reliability	<---	Extraversion	.339	.076	4.446	***	accept
Assurance	<---	Extraversion	.248	.081	3.053	.002	accept
Responsiveness	<---	Extraversion	.298	.081	3.691	***	accept
Empathy	<---	Extraversion	.267	.084	3.165	.002	accept
Tangibles	<---	Extraversion	.256	.082	3.138	.002	accept
Reliability	<---	Agreeablenes	.221	.070	3.152	.002	accept
Assurance	<---	Agreeablenes	.162	.076	2.146	.032	accept
Responsiveness	<---	Agreeablenes	.197	.075	2.630	.009	accept
Empathy	<---	Agreeablenes	.169	.078	2.160	.031	accept
Tangibles	<---	Agreeablenes	.235	.076	3.077	.002	accept

The results of SEM analysis (Table 7) show that openness has a positive and significant impact on Reliability (Regression Weights = 0.202 and p-value = 0.009). The factor openness has a positive and significant effect on assurance (Regression Weights = 0.37 and p-value = 0.000). The openness factor has a positive and significant impact on the responsiveness factor (Regression Weights = 0.291 and p-value=000); The openness factor has a positive and significant impact on the empathy factor (Regression Weights =0.300 and p-value=000); The openness factor has a positive and significant impact on the intangibles factor (Regression Weights =0.190 and p-value=.024). With this result, hypothesis H1. Openness has a positive and significant impact on five factors (reliability, assurance, intangibles, empathy, and responsiveness) that are accepted ([Shomirzayev, 2021](#); [Kurmanbay, 2020](#)).

The conscientiousness factor positively and significantly impacts the reliability factor (Regression Weights =0.266 and p-value=000). The conscientiousness factor positively and significantly impacts the assurance factor (Regression Weights =0.359 and p-value=000). The conscientiousness factor has a positive and significant impact on the responsiveness factor (Regression Weights =0.336 and p-value=000); The conscientiousness factor has a positive and significant impact on the empathy factor (Regression Weights = 0 .345 and p-value = 000); The conscientiousness factor has a positive and significant impact on the intangibles factor (Regression Weights =0.278 and p-value=000). With this result, hypothesis H2. Personality conscientiousness positively impacts the five accepted factors (reliability, assurance, intangibles, empathy, and responsiveness).

The neuroticism factor positively and significantly impacts the reliability factor (Regression Weights =0 .178 and p-value=0.009). The neuroticism factor had a positive and significant effect on the assurance factor (Regression Weights =0.154 and p-value=0.036). The neuroticism factor did not have a positive and significant effect on the responsiveness factor (Regression Weights =0.101 and p-value=0.160); The neuroticism factor did not have a positive and significant effect on the empathy factor (Regression Weights =0.108 and p-value=0.153); The neuroticism factor has a positive and significant impact on the intangibles factor (Regression Weights =0.166 and p-value=0.024). Because neuroticism has no positive and significant effect on the responsiveness factor and neuroticism has no positive and significant impact on empathy, hypothesis H3. Extraversion positively impacts five factors (reliability, assurance, intangibles, empathy, and responsiveness) that are not accepted (Vocroix, 2021; Nyandra et al., 2018).

The extraversion factor has a positive and significant effect on the reliability factor (Regression Weights =0.399 and p-value=000). The extraversion factor has a positive and significant effect on the assurance factor (Regression Weights =0.248 and p-value=0.002); The extraversion factor has a positive and significant impact on the responsiveness factor (Regression Weights =0.298 and p-value=000). The extraversion factor has a positive and significant impact on the empathy factor (Regression Weights =0.267 and p-value=0.002); The extraversion factor has a positive and significant impact on the empathy factor (Regression Weights =0.267 and p-value=0.002); The extraversion factor has a positive and significant impact on the intangibles factor (Regression Weights =0.256 and p-value=0.002). With this result, hypothesis H4. Agreeableness has a positive and significant impact with five accepted factors (reliability, assurance, intangibles, empathy, and responsiveness).

The agreeableness factor positively and significantly affects the reliability factor (Regression Weights =0.221 and p-value=0.002). The agreeableness factor has a positive and significant effect on the assurance factor (Regression Weights =0.162 and p-value=0.032). The factor agreeableness has a positive and significant impact on the responsiveness factor (Regression Weights =0 .197 and p-value=0.009); The agreeableness factor has a positive and significant impact on the empathy factor (Regression Weights =0.196 and p-value=0.031); The agreeableness factor has a positive and significant impact on the intangibles factor (Regression Weights =0.235 and p-value=0.002). With this result,

hypothesis H5. Neuroticism has a positive and significant impact on five factors (reliability, assurance, intangibles, empathy, and responsiveness) that are accepted.

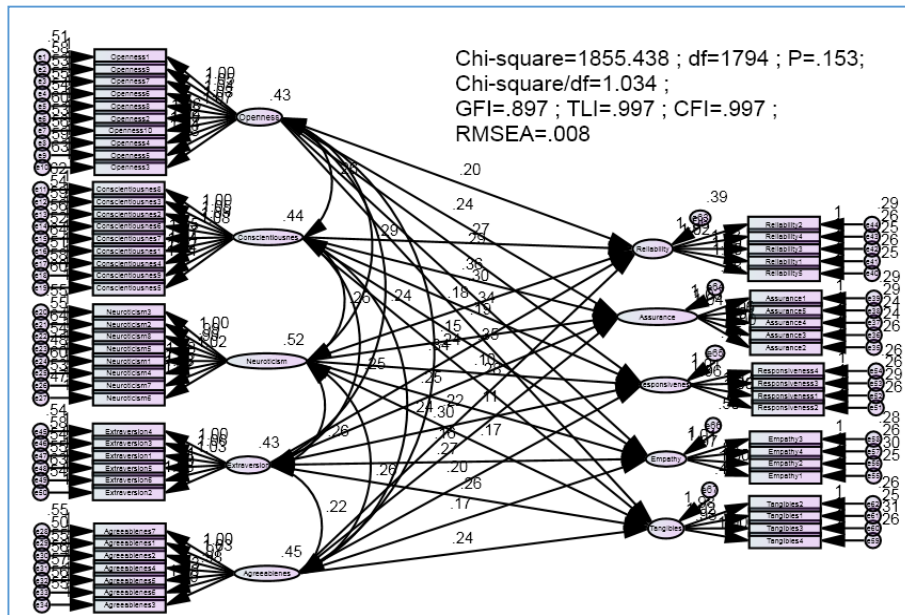

Figure 1. SEM analysis results

About model fit: Analysis results (Chart 1) for Mr. Chi-square=1855.438; Df=1794; P-value=0.153; Chi-square/df=1.034; GFI=0.879; TLI=0.997; CFI=0.997; RMSEA=0.008. Thus, all coefficients meet the requirements. Particularly for a GFI of approximately 0.9 is acceptable (Browne & Cudeck, 1993; Tucker & Lewis, 1973; Bentler, 1990; Browne & Cudeck, 1993; Byrne, 2012; Hu & Bentler 1999; Kline, 2015). Comparing the Regression Weights coefficients in Table 7: it is found that the personality traits of openness, conscientiousness and extraversion all have a positive and significant impact on five factors (reliability, assurance, intangibles, empathy, responsiveness) in the SERVQUAL model in Moderate. At a low level, the agreeableness factor positively impacts the five factors (reliability, assurance, intangibles, empathy, and responsiveness). Meanwhile, the neuroticism factor did not positively and significantly impact the five factors (reliability, assurance, intangibles, empathy, and responsiveness).

## Discussion

### Key findings

*Firstly*, the study found a positive and significant relationship between openness personality for five factors (reliability, assurance, tangibles, empathy, and responsiveness). This result is similar to the Castillo (2017) study in the private sector. The author believes that openness consumers show a strong relationship with service satisfaction. It means that people often focus on imagination and

deep understanding and tend to be curious about everything around them, creative, and always ready to learn new things and practice. Focus on overcoming satisfaction challenges with public services in Vietnam (John et al., 2008; McCrae & Costa, 2008; Barrick & Mount 1991).

*Second*, the study found that conscientiousness positively impacts five factors (reliability, assurance, intangibles, empathy, and responsiveness). This result is similar to the study of Castillo (2017) in the private sector. The author suggests that consumers associated with conscientiousness personality traits will also tend to feel more satisfied with services, meaning that individuals with conscientiousness personality traits exhibit a strong relationship with conscientiousness Satisfaction for Castillo service (2017). People who are thoughtful, manage their anger, and have explicit goals are satisfied with public service in Vietnam (John et al., 2008; McCrae & Costa, 2008; Barrick & Mount, 1991).

*Third*, the study found how extraversion has a positive and significant impact on five factors (reliability, assurance, intangibles, empathy, and responsiveness). This result is similar to the study of banking services in Macedonia (Ciunova-Shuleska & Palamidovska-Sterjadovska, 2019). The author discovered that extraversion personality positively affects customer satisfaction (Ciunova-Shuleska & Palamidovska-Sterjadovska, 2019). People who feel comfortable and energetic when participating in social activities, enjoy being the center of attention, active when in social relations are satisfied with public services in Vietnam (John et al., 2008; McCrae & Costa, 2008; Barrick & Mount 1991).

*Fourth*, the study finds how agreeableness has a positive and significant impact on five factors (reliability, assurance, tangibles, empathy, and responsiveness). It means that people with trust, altruism, kindness, and understanding are the essential characteristics of pleasantness, friendliness, cooperation and enthusiasm, and are satisfied with public services in Vietnam. This result is similar to the study (Siddiqui, 2012). The author argues that the personality dimensions agreeableness (humility, altruism, and trust) consistently provide the main predictive power of predicting customer satisfaction for the two services (Siddiqui, 2012). This result is similar to the study (Castillo, 2017). The author suggests that consumers with agreeableness personality traits will tend to feel more satisfied with services and have a strong relationship with customer satisfaction (Castillo, 2017).

*Fifth*, contrary to the research hypothesis, neuroticism has no positive and significant impact on five factors (reliability, assurance, intangibles, empathy, and responsiveness), so hypothesis H5 is not accepted due to neuroticism's impact on responsiveness empathy is not statistically significant. However, personality factor neuroticism has a positive and significant impact on reliability, assurance and intangibles factors. This study is similar to Wang et al. (2010), study in the retail sector in Beijing, China. The author found neuroticism to reduce the association between customer satisfaction and loyalty.

## **Implications**

At all levels in Vietnam, governments and authorities should consider consumers' personality characteristics (people, businesses, socio-political organizations) about their satisfaction with services. In order to identify customer characteristics, customer personality data should be used as one of the variables as a basis for dividing the respective public service market and positioning the corresponding services. Not only that, the information about the customer's personality helps managers and public service organizations better describe their customer base (Al-Hawari, 2015).

## **Limitations**

As with other empirical studies, there are limitations to this study that should be considered when discussing the results. First, our survey method reflects the subjective perception of the respondents towards the questions being investigated. Subjective data has some inherent disadvantages that are hard to avoid in surveys (Pakpour et al., 2014). Our data is collected over a single period. Moreover, cross-sectional data may affect the applicability of our results (Xin et al., 2019). So, Future research should combine cross-sectional and longitudinal studies. Another limitation is the language barrier. Although the method of translating the questionnaire from English to Vietnamese has been adjusted four times, there are still subjective attitudes of the translator. Therefore, it affects the perception and understanding of the respondents.

## **Conclusion**

At all levels in Vietnam, governments and authorities should consider consumers' personality characteristics (people, businesses, socio-political organizations) about their satisfaction with services. In order to identify customer characteristics, customer personality data should be used as one of the variables as a basis for dividing the respective public service market and positioning the corresponding services. The information about the customer's personality helps managers and public service organizations. This research provides insight to public service management and organizations on how they can learn more about their clients, which will assist them in providing better service. How to address personality traits related to customer satisfaction, which could form a fundamental theme in the customer-oriented public service delivery process, could lead to a model-new to handling customer interactions. It is the first study to explore the relationship between personality traits and guest satisfaction on public services in Vietnam. More similar studies are needed to fill the theoretical gap between personality traits and customer satisfaction.

## **References**

Ahmed, R., & Samreen, H. (2011). Assessing the Service quality of some selected hospitals in Karachi based on the SERVQUAL model. *Pakistan Business Review*, 32(5), 266-314.

- Akrami, N., Ekehammar, B., & Bergh, R. (2011). Generalized prejudice: Common and specific components. *Psychological Science, 22*(1), 57-59.
- Al-Hawari, M. A. (2015). How the personality of retail bank customers interferes with the relationship between service quality and loyalty. *International Journal of Bank Marketing.*
- Allik, J., & McCrae, R. R. (2004). Toward a geography of personality traits: Patterns of profiles across 36 cultures. *Journal of cross-cultural psychology, 35*(1), 13-28.
- Anitsal, M. M., & Anitsal, I. (2009). Impact Of Customers'personality Traits In Retail Environments. *Academy of Strategic Management Journal, 8*, 39.
- Arshad, A., & Ameen, K. (2010). Service quality of the University of the Punjab's libraries: An exploration of users' perceptions. *Performance Measurement and Metrics.*
- Ashton, M. C., Paunonen, S. V., & Lee, K. (2014). On the validity of narrow and broad personality traits: A response to. *Personality and Individual Differences, 56*, 24-28. <https://doi.org/10.1016/j.paid.2013.08.019>
- Asubonteng, P., McCleary, K. J., & Swan, J. E. (1996). SERVQUAL revisited: a critical review of service quality. *Journal of Services marketing.*
- Barrick, M. R., & Mount, M. K. (1991). The big five personality dimensions and job performance: a meta-analysis. *Personnel psychology, 44*(1), 1-26.
- Barrick, M. R., Mount, M. K., & Judge, T. A. (2001). Personality and performance at the beginning of the new millennium: What do we know and where do we go next?. *International Journal of Selection and assessment, 9*(1-2), 9-30.
- Bentler, P. M. (1990). Comparative fit indexes in structural models. *Psychological bulletin, 107*(2), 238.
- Bhattacharya, S., Saha, S., & Banerjee, S. (2016). Income inequality and the quality of public services: A developing country perspective. *Journal of Development Economics, 123*, 1-17.
- Brose, L. A., Rye, M. S., Lutz-Zois, C., & Ross, S. R. (2005). Forgiveness and personality traits. *Personality and individual differences, 39*(1), 35-46. <https://doi.org/10.1016/j.paid.2004.11.001>
- Brown, E. E., Robertson, G. S., & Fibiger, H. C. (1992). Evidence for conditional neuronal activation following exposure to a cocaine-paired environment: role of forebrain limbic structures. *Journal of Neuroscience, 12*(10), 4112-4121.
- Brown, M. W., & Cudeck, R. (1993). Alternative ways of assessing model fit. *Testing structural equation models, 154*, 136-162.
- Brunner, M., & SÜß, H. M. (2005). Analyzing the reliability of multidimensional measures: An example from intelligence research. *Educational and Psychological Measurement, 65*(2), 227-240.
- Bryland, A., & Curry, A. (2001). Service improvements in public services using SERVQUAL. *Managing Service Quality: An International Journal.*
- Byrne, B. M. (2012). *A primer of LISREL: Basic applications and programming for confirmatory factor analytic models.* Springer Science & Business Media.
- Canli, T. (2008). Toward a "molecular psychology" of personality.
- Carney, D. R., Jost, J. T., Gosling, S. D., & Potter, J. (2008). The secret lives of liberals and conservatives: Personality profiles, interaction styles, and the things they leave behind. *Political psychology, 29*(6), 807-840.

- Caron, D. J., & Giauque, D. (2006). Civil servant identity at the crossroads: new challenges for public administrations. *International Journal of Public Sector Management*.
- Caspi, A., Roberts, B. W., & Shiner, R. L. (2005). Personality development: Stability and change. *Annu. Rev. Psychol.*, 56, 453-484.
- Castillo, J. (2017). The relationship between big five personality traits, customer empowerment and customer satisfaction in the retail industry. *Journal of Business and Retail Management Research (JBRMR)*, 11(2).
- Cerny, B. A., & Kaiser, H. F. (1977). A study of a measure of sampling adequacy for factor-analytic correlation matrices. *Multivariate behavioral research*, 12(1), 43-47.
- Ciunova-Shuleska, A., & Palamidovska-Sterjadovska, N. (2019). Model of satisfaction involving affect and personality traits. *Eurasian Business Review*, 9(4), 485-500.
- Ciunova-Shuleska, A., & Palamidovska-Sterjadovska, N. (2019). Model of satisfaction involving affect and personality traits. *Eurasian Business Review*, 9(4), 485-500.
- Cortina, J. M. (1993). What is coefficient alpha? An examination of theory and applications. *Journal of applied psychology*, 78(1), 98.
- Cronin Jr, J. J., & Taylor, S. A. (1994). SERVPERF versus SERVQUAL: reconciling performance-based and perceptions-minus-expectations measurement of service quality. *Journal of marketing*, 58(1), 125-131.
- Crowley, S. L., & Fan, X. (1997). Structural equation modeling: Basic concepts and applications in personality assessment research. *Journal of personality assessment*, 68(3), 508-531.
- Denissen, J. J., & Penke, L. (2008). Motivational individual reaction norms underlying the Five-Factor model of personality: First steps towards a theory-based conceptual framework. *Journal of research in personality*, 42(5), 1285-1302.
- Dotchin, J. A., & Oakland, J. S. (1994). Total quality management in services: Part 1: Understanding and classifying services. *International Journal of Quality & Reliability Management*.
- Ekehammar, B., & Akrami, N. (2003). The relation between personality and prejudice: a variable-and a person-centred approach. *European Journal of Personality*, 17(6), 449-464.
- Epple, D., & Romano, R. E. (1996). Ends against the middle: Determining public service provision when there are private alternatives. *Journal of Public Economics*, 62(3), 297-325. [https://doi.org/10.1016/0047-2727\(95\)01540-X](https://doi.org/10.1016/0047-2727(95)01540-X)
- Fornell, C., & Larcker, D. F. (1981). Evaluating structural equation models with unobservable variables and measurement error. *Journal of marketing research*, 18(1), 39-50.
- Francis, L. E. (1994). Laughter, the best mediation: Humor as emotion management in interaction. *Symbolic Interaction*, 17(2), 147-163.
- Francois, P. (2000). 'Public service motivation' as an argument for government provision. *Journal of Public Economics*, 78(3), 275-299. [https://doi.org/10.1016/S0047-2727\(00\)00075-X](https://doi.org/10.1016/S0047-2727(00)00075-X)
- Gerber, A. S., Huber, G. A., Doherty, D., & Dowling, C. M. (2011). The big five personality traits in the political arena. *Annual Review of Political Science*, 14, 265-287.

- Gerber, A. S., Huber, G. A., Doherty, D., Dowling, C. M., & Ha, S. E. (2010). Personality and political attitudes: Relationships across issue domains and political contexts. *American Political Science Review*, *104*(1), 111-133.
- Gerber, A. S., Huber, G. A., Doherty, D., Dowling, C. M., Raso, C., & Ha, S. E. (2011). Personality traits and participation in political processes. *The Journal of Politics*, *73*(3), 692-706.
- Gowan, M., Seymour, J., Ibarreche, S., & Lackey, C. (2001). Service quality in a public agency: same expectations but different perceptions by employees, managers, and customers. *Journal of Quality Management*, *6*(2), 275-291.
- Gronroos, C. (1988). Service quality: The six criteria of good perceived service. *Review of business*, *9*(3), 10.
- Grönroos, J. A. (1957). Investigations on Escherichia coli O Groups 1-25, 44 and 78 and Sero-Types 26: B6, 55: B5, 86: B7, 111: B4, 125: B15 and 126: B16. Occurrence in Faeces of Healthy and Diarrhoeal Infants. *Ann. Med. Exper. et Biol. Fenniae*, *35*(Suppl. 2).
- Hair, J. F., Anderson, R. E., Tatham, R. L., & Black, W. C. (1998). Factorial analysis. *Multivariate Data Analysis. Fifth edition. New Jersey: Prentice Hall*.
- Hair, J. F., Anderson, R. E., Tatham, R. L., & Black, W. C. (1998). Multivariate Data Analysis, 5th ed Prentice-Hall. *Englewood Cliffs, NJ*.
- Hair, J. F., Celsi, M., Ortinau, D. J., & Bush, R. P. (2010). *Essentials of marketing research* (Vol. 2). New York, NY: McGraw-Hill/Irwin.
- Hampson, S. E., & Goldberg, L. R. (2006). A first large cohort study of personality trait stability over the 40 years between elementary school and midlife. *Journal of personality and social psychology*, *91*(4), 763.
- Heine, S. J., & Buchtel, E. E. (2009). Personality: The universal and the culturally specific. *Annual review of psychology*, *60*, 369-394.
- Hu, L. T., & Bentler, P. M. (1999). Cutoff criteria for fit indexes in covariance structure analysis: Conventional criteria versus new alternatives. *Structural equation modeling: a multidisciplinary journal*, *6*(1), 1-55.
- Jackson, J. W., & Poulsen, J. R. (2005). Contact experiences mediate the relationship between five-factor model personality traits and ethnic prejudice. *Journal of Applied Social Psychology*, *35*(4), 667-685.
- Jin, L., Watkins, D., & Yuen, M. (2009). Personality, career decision self-efficacy and commitment to the career choices process among Chinese graduate students. *Journal of Vocational Behavior*, *74*(1), 47-52.
- Johansson, E., Diwan, V. K., Huong, N. D., & Ahlberg, B. M. (1996). Staff and patient attitudes to tuberculosis and compliance with treatment: an exploratory study in a district in Vietnam. *Tubercle and Lung Disease*, *77*(2), 178-183. [https://doi.org/10.1016/S0962-8479\(96\)90035-0](https://doi.org/10.1016/S0962-8479(96)90035-0)
- John, O. P., & Srivastava, S. (1999). *The Big-Five trait taxonomy: History, measurement, and theoretical perspectives* (Vol. 2, pp. 102-138). Berkeley: University of California.
- John, O. P., Naumann, L. P., & Soto, C. J. (2008). Paradigm shift to the integrative Big Five trait taxonomy: History, measurement, and conceptual issues.
- Joseph Jr, F. (2014). Hair Jr, William C. Black, Barry J. Babin, Rolph E. Anderson.(2013). *Multivariate data analysis*.
- Jost, J. T. 2006. *The end of the end of ideology*. *American Psychologist*, *61*, 651-670.

- Jost, J. T., Nosek, B. A., & Gosling, S. D. (2008). Ideology: Its resurgence in social, personality, and political psychology. *Perspectives on Psychological Science*, 3(2), 126-136.
- Kaiser, H. F. (1974). An index of factorial simplicity. *Psychometrika*, 39(1), 31-36.
- Kettinger, W. J., & Lee, C. C. (1994). Perceived service quality and user satisfaction with the information services function. *Decision sciences*, 25(5-6), 737-766.
- Khan, S., Arshad, M. A., Mahmood, A., & Khan, Q. (2020). Proposed Soul Management Model for Organizational Performance: An Islamic Perspective. *Journal of Talent Development and Excellence*, 12(2s), 3624-3634.
- Khanh, V. N. (2011). *Measuring the satisfaction of the people for public administrative services when applying ISO in District No. 1-Ho Chi Minh City* (Doctoral dissertation, Thesis at University of Economics Ho Chi Minh City).
- Kim, S. H., Kim, M. S., & Lee, D. H. (2016). The effects of personality traits and congruity on customer satisfaction and brand loyalty: Evidence from coffee shop customers. In *Advances in Hospitality and Leisure*. Emerald Group Publishing Limited.
- Kline, R. B. (2015). *Principles and practice of structural equation modeling*. Guilford publications.
- Kumasey, A. S. (2014). Service quality and customer satisfaction: Empirical evidence from the Ghanaian public service. *European Journal of Business and Management*, 6(6), 172-181.
- Kurmanbay, G. (2020). The role of the subject “literature” in forming personality in modern secondary schools. *International Journal of Linguistics, Literature and Culture*, 6(4), 1-5. <https://doi.org/10.21744/ijllc.v6n4.900>
- Lewis, B. R., & Mitchell, V. W. (1990). Defining and measuring the quality of customer service. *Marketing intelligence & planning*.
- Lewis, R. C., & Booms, B. H. (1983). The marketing aspects of service quality. *Emerging perspectives on services marketing*, 65(4), 99-107.
- Lin, R. J., Tan, K. H., & Geng, Y. (2013). Market demand, green product innovation, and firm performance: evidence from Vietnam motorcycle industry. *Journal of Cleaner Production*, 40, 101-107. <https://doi.org/10.1016/j.jclepro.2012.01.001>
- Linde, A. (2021). Keeping the personality in the information societies: The application of J. Habermas’s approach. *Linguistics and Culture Review*, 5(S4), 1252-1269. <https://doi.org/10.21744/lingcure.v5nS4.1760>
- Marušić, I., Kamenov, Ž., & Jelić, M. (2011). Personality and attachment to friends. *Društvena istraživanja*, 20(4), 1119-1137.
- Mattila, M. L., Kielinen, M., Linna, S. L., Jussila, K., Ebeling, H., Bloigu, R., ... & Moilanen, I. (2011). Autism spectrum disorders according to DSM-IV-TR and comparison with DSM-5 draft criteria: an epidemiological study. *Journal of the American academy of child & adolescent psychiatry*, 50(6), 583-592.
- McCrae, R. R., & Costa Jr, P. T. (2008). The five-factor theory of personality.
- Medland, S. E., & Hatemi, P. K. (2009). Political science, biometric theory, and twin studies: A methodological introduction. *Political Analysis*, 17(2), 191-214.
- Mischel, W., & Shoda, Y. (1995). A cognitive-affective system theory of personality: reconceptualizing situations, dispositions, dynamics, and invariance in personality structure. *Psychological review*, 102(2), 246.

- Mondak, J. J. (2010). *Personality and the foundations of political behavior*. Cambridge University Press.
- Mondak, J. J., & Halperin, K. D. (2008). A behaviour. *British Journal of Political Science*.
- Mondak, J. J., Hibbing, M. V., Canache, D., Seligson, M. A., & Anderson, M. R. (2010). Personality and civic engagement: An integrative framework for the study of trait effects on political behavior. *American political science review*, 104(1), 85-110.
- Mukhtar, H., Saeed, A., & Ata, G. (2013). Measuring service quality in Public Sector using SERVQUAL: a case of Punjab Dental Hospital, Lahore. *Research on Humanities and Social Sciences*, 3(22), 65-70.
- Musatova, Z., Skorobogatykh, I., & Zavyalova, N. (2009). Customer Personal Values, Individuality and Purchase Experience Linked with Customer Satisfaction (Results of empirical study of young consumers in Russia).
- Nachtigall, C., Kroehne, U., Funke, F., & Steyer, R. (2003). Pros and cons of structural equation modeling. *Methods Psychological Research Online*, 8(2), 1-22.
- Nadiha, M. N., Fazilah, A., Bhat, R., & Karim, A. A. (2010). Comparative susceptibilities of sago, potato and corn starches to alkali treatment. *Food Chemistry*, 121(4), 1053-1059.
- Ngo, V. M., & Nguyen, H. H. (2016). The relationship between service quality, customer satisfaction and customer loyalty: An investigation in Vietnamese retail banking sector. *Journal of Competitiveness*.
- Nigro, H. O., & Císaro, S. E. G. (2016). The citizen satisfaction index: Adapting the model in Argentine cities. *Cities*, 56, 85-90. <https://doi.org/10.1016/j.cities.2016.03.010>
- Nitecki, D. A. (1996). Changing the concept and measure of service quality in academic libraries. *The journal of academic librarianship*, 22(3), 181-190.
- Nyandra, M., Kartiko, B.H., Susanto, P.C., Supriyati, A., Suryasa, W. (2018). Education and training improve quality of life and decrease depression score in elderly population. *Eurasian Journal of Analytical Chemistry*, 13(2), 371-377.
- Pakpour, A. H., Gellert, P., Asefzadeh, S., Updegraff, J. A., Molloy, G. J., & Sniehotta, F. F. (2014). Intention and planning predicting medication adherence following coronary artery bypass graft surgery. *Journal of Psychosomatic Research*, 77(4), 287-295.
- Parasuraman, A., Berry, L. L., & Zeithaml, V. A. (1991). Understanding customer expectations of service. *Sloan management review*, 32(3), 39-48.
- Parasuraman, A., Berry, L. L., & Zeithaml, V. A. (1993). Research note: More on improving quality measurement. *Journal of retailing*, 69(1), 140.
- Parasuraman, A., Zeithaml, V. A., & Berry, L. (1988). SERVQUAL: A multiple-item scale for measuring consumer perceptions of service quality. 1988, 64(1), 12-40.
- Parasuraman, A., Zeithaml, V. A., & Berry, L. L. (1985). A conceptual model of service quality and its implications for future research. *Journal of marketing*, 49(4), 41-50.
- Parasuraman, A., Zeithaml, V. A., & Berry, L. L. (1994). Reassessment of expectations as a comparison standard in measuring service quality: implications for further research. *Journal of marketing*, 58(1), 111-124.

- Phap, V. M., Huong, N. T. T., Hanh, P. T., Van Duy, P., & Van Binh, D. (2020). Assessment of rooftop solar power technical potential in Hanoi city, Vietnam. *Journal of Building Engineering*, 32, 101528. <https://doi.org/10.1016/j.jobe.2020.101528>
- Rammstedt, B., & John, O. P. (2007). Measuring personality in one minute or less: A 10-item short version of the Big Five Inventory in English and German. *Journal of research in Personality*, 41(1), 203-212.
- Ramos, R. I. A., Mata, R. R. M., & Nacar, R. C. (2021). Mediating effect of ethical climate on the relationship of personality types and employees mindfulness. *Linguistics and Culture Review*, 5(S1), 1480-1494. <https://doi.org/10.21744/lingcure.v5nS1.1722>
- Ramseook Munhurrun, P., Naidoo, P., & Lukea-Bhiwajee, S. D. (2010). Measuring service quality: Perceptions of employees. *Global journal of business research*, 4(1), 47-58.
- Ramseook-Munhurrun, P., Lukea-Bhiwajee, S. D., & Naidoo, P. (2010). Service quality in the public service. *International journal of management and marketing research*, 3(1), 37-50.
- Raykov, T. (1997). Estimation of composite reliability for congeneric measures. *Applied Psychological Measurement*, 21(2), 173-184.
- Raykov, T., & Marcoulides, G. A. (2006). On multilevel model reliability estimation from the perspective of structural equation modeling. *Structural Equation Modeling*, 13(1), 130-141.
- Ringold, D., Holla, A., Koziol, M., & Srinivasan, S. (2011). *Citizens and service delivery: assessing the use of social accountability approaches in human development sectors*. World Bank Publications.
- Rowley, J. (1998). Quality measurement in the public sector: Some perspectives from the service quality literature. *Total Quality Management*, 9(2-3), 321-333.
- Schmitt, D. P., Allik, J., McCrae, R. R., & Benet-Martínez, V. (2007). The geographic distribution of Big Five personality traits: Patterns and profiles of human self-description across 56 nations. *Journal of cross-cultural psychology*, 38(2), 173-212.
- Shaw, R. P. (2004). *New Trends in Public Sector Management in Health: applications in developed and developing countries*. World Bank, Washington, DC.
- Shomirzayev, S. (2021). National followers in the students use of educational technologies instruction of interests. *International Journal of Linguistics, Literature and Culture*, 7(3), 152-157. <https://doi.org/10.21744/ijllc.v7n3.1508>
- Sibley, C. G., & Duckitt, J. (2008). Personality and prejudice: A meta-analysis and theoretical review. *Personality and Social Psychology Review*, 12(3), 248-279.
- Siddiqui, K. (2012). Personality influences on customer satisfaction. *African Journal of Business Management*, 6(11), 4134-4141.
- Silvestri, T. J., & Richardson, T. Q. (2001). White racial identity statuses and NEO personality constructs: An exploratory analysis. *Journal of Counseling & Development*, 79(1), 68-76.
- Smith, K. B., Oxley, D. R., Hibbing, M. V., Alford, J. R., & Hibbing, J. R. (2011). Linking genetics and political attitudes: Reconceptualizing political ideology. *Political Psychology*, 32(3), 369-397.

- Smith, R. M., & Miao, C. Y. (1994). Assessing unidimensionality for Rasch measurement. *Objective measurement: Theory into practice*, 2, 316-327.
- Snedecor, G. W., & Cochran, W. G. (1989). *Statistical Methods*, eighth edition. Iowa state University press, Ames, Iowa, 1191.
- Tan, T. H., & Waheed, A. (2011). Herzberg's motivation-hygiene theory and job satisfaction in the Malaysian retail sector: The mediating effect of love of money.
- Terracciano, A., McCrae, R. R., & Costa Jr, P. T. (2010). Intra-individual change in personality stability and age. *Journal of research in personality*, 44(1), 31-37.
- Tucker, L. R., & Lewis, C. (1973). A reliability coefficient for maximum likelihood factor analysis. *Psychometrika*, 38(1), 1-10.
- Ullman, J. B. (2006). Reviewing the basics and moving forward. *J Pers. Assess*, 87, 35-50.
- Uy, P. D., & Nakagoshi, N. (2008). Application of land suitability analysis and landscape ecology to urban greenspace planning in Hanoi, Vietnam. *Urban Forestry & Urban Greening*, 7(1), 25-40. <https://doi.org/10.1016/j.ufug.2007.09.002>
- Vandamme, R., & Leunis, J. (1993). Development of a multiple-item scale for measuring hospital service quality. *International Journal of Service Industry Management*, 4(3), 0-0.
- Vocroix, L. (2021). Morphology in micro linguistics and macro linguistics. *Macrolinguistics and Microlinguistics*, 2(1), 1–20. Retrieved from <https://mami.nyc/index.php/journal/article/view/11>
- Wang, K., Li, M., & Hakonarson, H. (2010). ANNOVAR: functional annotation of genetic variants from high-throughput sequencing data. *Nucleic acids research*, 38(16), e164-e164.
- Widaman, K. F., & Reise, S. P. (1997). Exploring the measurement invariance of psychological instruments: Applications in the substance use domain.
- Wisniewski, M. (1996). Measuring service quality in the public sector: the potential for SERVQUAL. *Total Quality Management*, 7(4), 357-366.
- Wisniewski, M. (2001). Using SERVQUAL to assess customer satisfaction with public sector services. *Managing Service Quality: An International Journal*.
- Xin, Z., Liang, M., Zhanyou, W., & Hua, X. (2019). Psychosocial factors influencing shared bicycle travel choices among Chinese: An application of theory planned behavior. *PloS one*, 14(1), e0210964.
- Yamagata, S., Suzuki, A., Ando, J., Ono, Y., Kijima, N., Yoshimura, K., ... & Jang, K. L. (2006). Is the genetic structure of human personality universal? A cross-cultural twin study from North America, Europe, and Asia. *Journal of personality and social psychology*, 90(6), 987.
- Žabkar, V., & Kolar, T. (2010). Consumers in Slovenia: values, personality types and consumerist attitudes. *Market-Tržište*, 22(2), 205-222.
- Zakaria, Z., Hussin, Z. H., Batau, M. F. A., & Zakaria, Z. (2010). Service quality of Malaysian public transports: a case study in Malaysia. *Cross-Cultural Communication*, 6(2), 84-92.
- Zenker, S., & Rütter, N. (2014). Is satisfaction the key? The role of citizen satisfaction, place attachment and place brand attitude on positive citizenship behavior. *Cities*, 38, 11-17. <https://doi.org/10.1016/j.cities.2013.12.009>